

The Art of Photography

A Reading A-Z Level Y Leveled Book

Word Count: 2,104



Reading a-z

Visit www.readinga-z.com
for thousands of books and materials.

LEVELED BOOK • Y

THE ART OF PHOTOGRAPHY



Written by Jeffrey B. Fuerst

www.readinga-z.com

THE ART OF PHOTOGRAPHY



Written by Jeffrey B. Fuerst

www.readinga-z.com

Photo Credits:

Front cover, pages 15 (all), 16 (all), 17, 18, 19 (all), 22 (all), 23 (all), 24 (all): Francis Morgan/© Learning A-Z; back cover, page 8: courtesy of Library of Congress, Prints and Photographs Div [LC-USZ62-35617]; title page, page 13: © 123RF; page 4: © iStockphoto.com/Jan-Dirk Hansen; page 7: courtesy of Library of Congress, Prints & Photographs Div [LC-USZC4-10110]; page 9: © iStockphoto.com/Joseph T. Ryczaj Photography; page 10 (top): © Alex Melnick/Dreamstime.com; page 10 (bottom): © iStockphoto.com; page 11 (top): iStockphoto.com/W.R. Mayes; page 11 (bottom): © iStockphoto.com/Jaroslav Wojcik; page 12 (top, bottom): © Jupiterimages Corporation; page 14: © Learning A-Z

The Art of Photography
Level Y Leveled Book
© Learning A-Z
ISBN 1-59827-714-6
Written by Jeffrey B. Fuerst
Illustrated by Cende Hill

All rights reserved.

www.readinga-z.com

Correlation

LEVEL Y	
Fountas & Pinnell	T
Reading Recovery	40
DRA	40

Table of Contents

Introduction	4
History of Photography	5
Try This! Make a Pinhole Camera	6
Modern Photography	10
Ready, Aim, Shoot: The Art of Photography	16
Lighting Dos and Don'ts.....	20
Fun Photography Projects	22
Explore More	25
Glossary	26
Index	26

Introduction

While on vacation, your dad drags you out of bed and down to the ocean for a 5:00 AM “whale watch”—yawn. But wait, look at that huge tail



rising out of the water! Good thing you brought along your camera. Photographs of whales at dawn, historical landmarks, or family members

doing wacky things preserve your amazing or amusing vacation memories forever.

Taking photographs nowadays is a snap. With inexpensive disposable cameras, basic “point-and-shoot” compact cameras, and digital cameras, all you need to do is aim and click away. That wasn’t so in the early days of photography, when taking pictures required expensive, **cumbersome** equipment, knowledge of chemistry, and lots of patience. And even though most people today use digital cameras, learning about film photography can help anyone who wants to take great photos.

History of Photography

The word “camera” comes from a Latin word meaning “chamber” or “dark room.” A camera is just that: a dark box with light-sensitive film or a chip on its back wall. When you “click” a camera, a **shutter** opens in the front, letting light into the box for a very short time. That light, reflected off an object, forms the image on the film or chip. The lens of the camera, like the lens of your eye, collects and focuses light onto the film or chip.

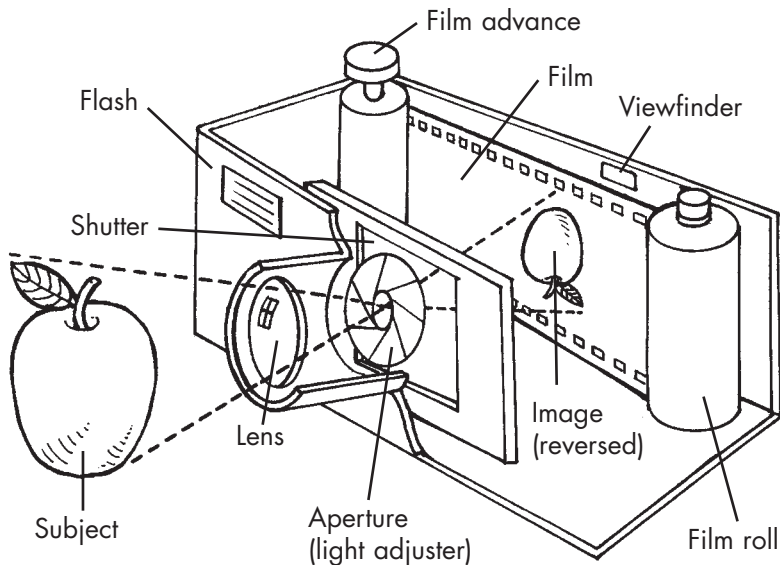

The first **crude** camera was invented around AD 1500. It could only project an image onto a screen or a piece of paper, like the pinhole camera in the project on the next page.

Try This!

Make A Pinhole Camera

- 1 Punch a pencil-point-sized hole in the side of a shoebox.
- 2 Cut out a 2-inch (5-cm) square on the opposite side of the shoebox.
- 3 Cut a square of tracing paper slightly larger than this opening and tape it over the opening.
- 4 Tape the top of the shoebox shut so that no light can get in.
- 5 Have someone stand still in bright light.
- 6 Aim the pinhole at him or her and look through the tracing paper. After a few seconds, you should see a small image of that person.

Notice anything unusual about the image you see? Try to trace the image on the tracing paper.

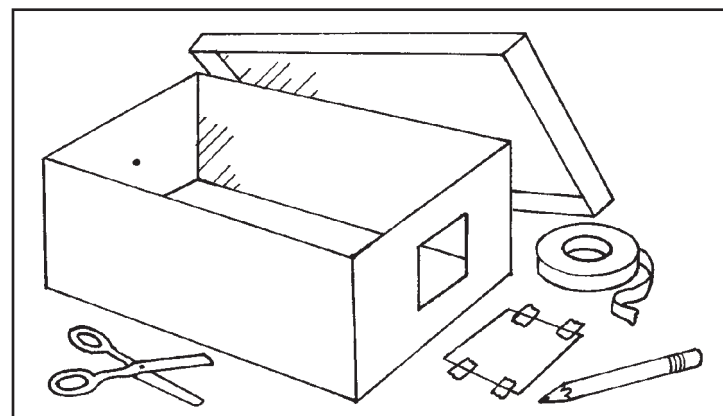



People had to hold very still for early cameras, or pictures would come out blurry, like the woman's face on the left.

It took a few hundred years and a series of scientific discoveries before people figured out how to make permanent images. First, they discovered that certain chemicals turn dark when exposed to light, and then they found a way to use other chemicals to keep the image from fading.

The earliest cameras took hours to record one blurry, black-and-white image. In the 1830s, a French inventor, Louis Daguerre, created a way to make sharp-looking pictures in less than thirty seconds. His images, called **daguerreotypes** (dah-GARE-oh-types) after their inventor, became the first popular form of photography.



Do You Know?

In the early days of photography, it could take half an hour to set up and take one photo. People, especially kids, got restless, but even a small movement during the taking of the picture would ruin it. Photographers would often hold up a metal bird and tell their subjects to "watch the birdie." Right before taking the picture, the photographer would blow air into the bird and make it move its tail or tweet. This often got the attention of the kids, and they would hold still.

It wasn't until the introduction of the Kodak® box camera in 1888 that photography became an affordable hobby. The Kodak camera was lightweight, inexpensive, and easy to operate. Best of all, **amateur** photographers did not have to go through the long, often **painstaking** process of developing the film. Like modern film cameras, the box camera recorded images on a roll of film. People sent the film, along with the camera, back to the company, where prints were made, and the camera was returned with a new roll of film inside.



Early box cameras look big now, but they were small for their time.

Modern Photography

These inexpensive cameras are the kind you will most likely use as you learn about photography.

1 Disposable Or Single-Use Camera



2 Basic Compact Camera

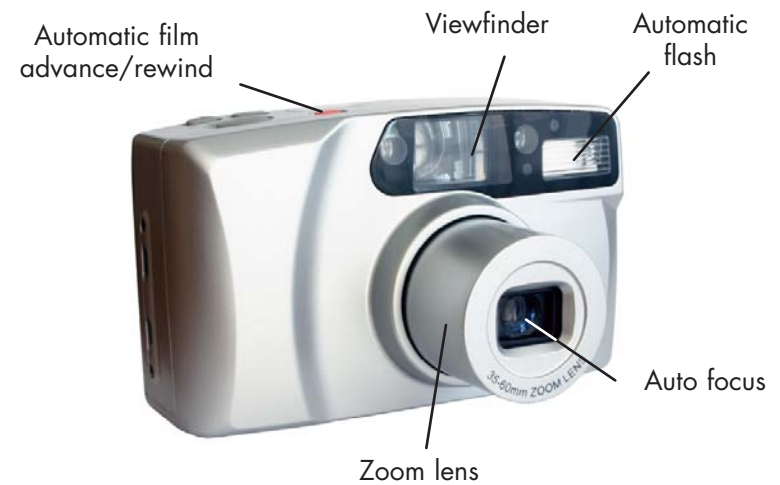

3 SLR (Single Lens Reflex) Camera



4 Digital Camera

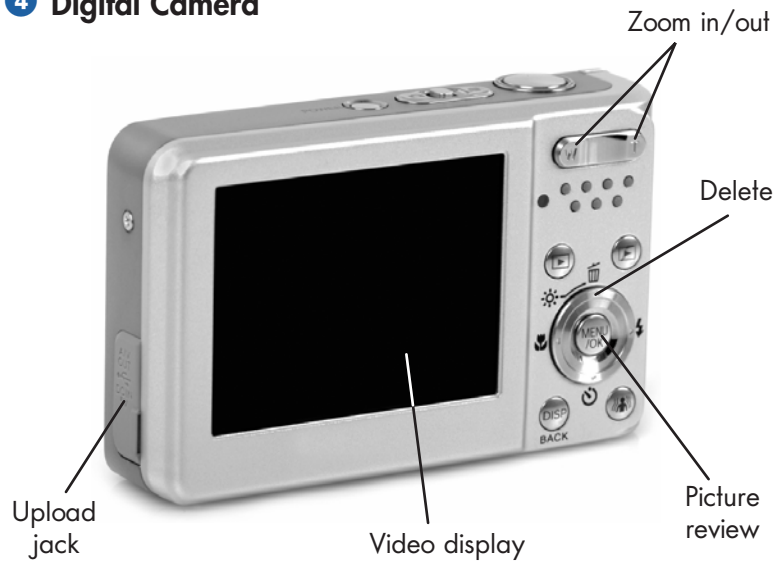

Today, many simple cameras use film. Film is a strip of plastic coated with a silver substance that is sensitive to light. When light strikes



this silver coating, its chemicals react, forming an image on the film. After you have taken your pictures, they need to go through a multiple-step process to become photographs. First, the film is placed in a chemical solution

called developer that makes the image visible.

Next, the film takes a “stop bath” in another chemical solution

that stops the developer before

the image becomes too dark.

Now you have a negative that

shows the reverse of the image; light

objects look dark,

and dark objects

look light.



A print, also called the positive, is an enlarged copy made from the negative. The developing process is reversed, starting with light projected through the negative onto light-sensitive photo paper. The paper records the reverse of the negative, so you see the image as originally recorded. Then a chemical “fixer” sets the image, or makes it permanent on the paper. Many professional photographers print photos in their own **darkrooms**, but you’ll probably send your film to your local photo lab, where the process is done by machine.



What are all those numbers on a roll of film? They tell you the film’s width, or format; its length; and most importantly, its speed. Most film is 35 millimeters wide. Its length, typically 24 or 36, tells you how many pictures you can take on that roll. The number you should note, depending on when and where you plan to take pictures, is the film’s ISO rating, or speed.

The film’s speed tells you how quickly it will react to light. A higher number means the film requires less light, so 400-speed film is better

for dim light and for action shots where you are trying to capture movement. Slower 100-speed film is better for outdoor shots taken in full daylight.

A good **multipurpose** film is 200-speed.



Choose the right film for the kind of pictures you want to take.

Ready, Aim, Shoot: The Art of Photography

Now that you know how cameras work, let's get clicking. First, you need to choose a subject, or something you want to take a picture of. It can be a person, a place, a thing—or all three!

Composition, or framing, is how you arrange what's in your picture. If your subject is a person, you want to fill the frame, but leave a little room around the person's head and shoulders. Keep your subject between the lines in the viewfinder or you may cut off the top of his head. That might be good for an "arty" look—or if you don't like him! Don't get too close, or the image may turn out fuzzy.

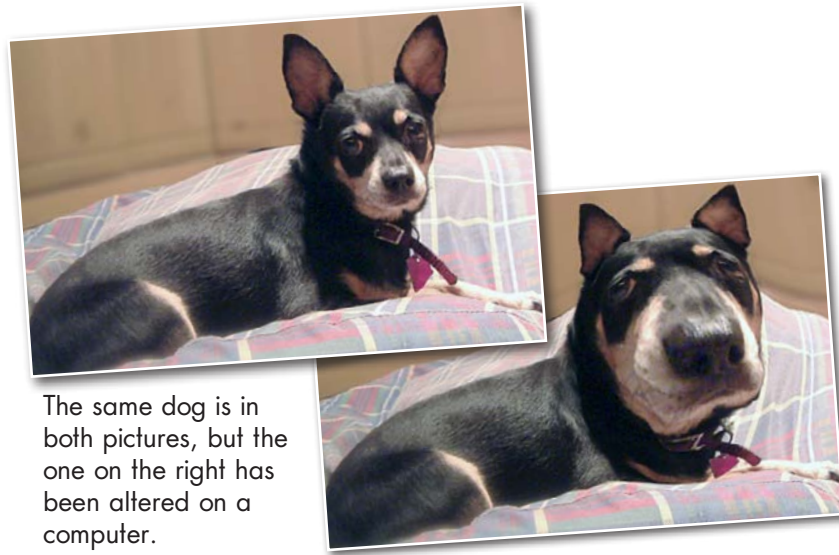

The same dog is in both pictures, but the one on the right has been altered on a computer.

Digital cameras work like other cameras, except they don't use film. Instead, reusable light-sensitive microchips store the images. Shots taken with a digital camera can be seen instantly on the screen. Don't like what you see? Delete the image and try again (remember, there is no film to waste). The shots you want can be transferred to a computer, where you can change them electronically. That's when the real fun of digital photography begins. Make the colors richer, put one photo into another, or remove something (or someone!) you don't want. Retouching, airbrushing, and other improvement tricks once done only by skilled photographers in darkrooms can now be done on a computer. But they still require the same artistic eye and lots of patience.



Bad composition (left) cuts off the subject's head and what he's looking at. Good composition (right) includes the whole subject and what he's doing.



Keep groups of people close together, both side-to-side and front-to-back.

Arrange a group of people so they're all about the same distance from the camera. Otherwise, the ones closer to the camera may look washed out and those in the back may look dark.

Experiment with composition, and don't be afraid to try things and make mistakes. Position your subject in the middle of the frame, and then off to the side. Shoot through a window or an archway. Look for interesting shapes and contrasts, such as a jagged fence against the curves of a hill.

Consider the angle—kneel down and shoot up at your subject to make it look more important. Hold the camera vertically for portraits. Emphasize the foreground (in the front part of the picture), and then try a similar shot emphasizing the background. Shots of scenery often look more interesting when there is a person in the foreground, giving the shot a sense of scale.

Watch the background . . . keep it simple, and make sure it doesn't look like something odd

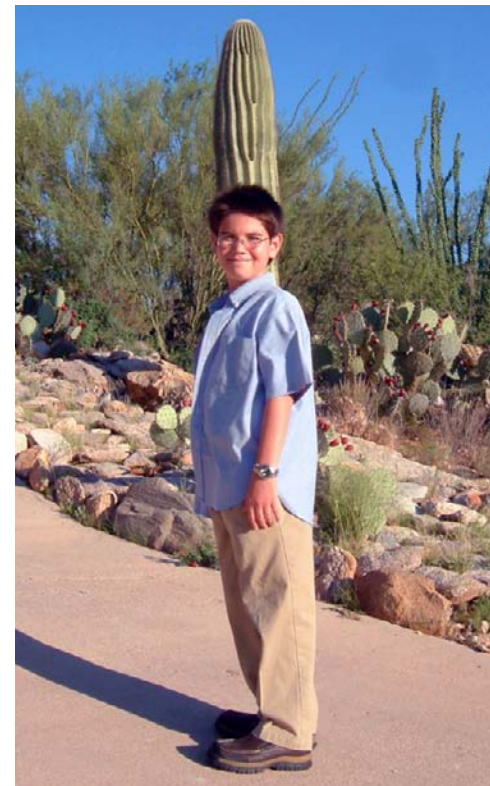

is sticking out of your subject's head. Remove clutter in the foreground that might take the focus away from your subject, or move yourself for a new perspective.

Pay attention to the background, or you might get a cactus growing out of someone's head!

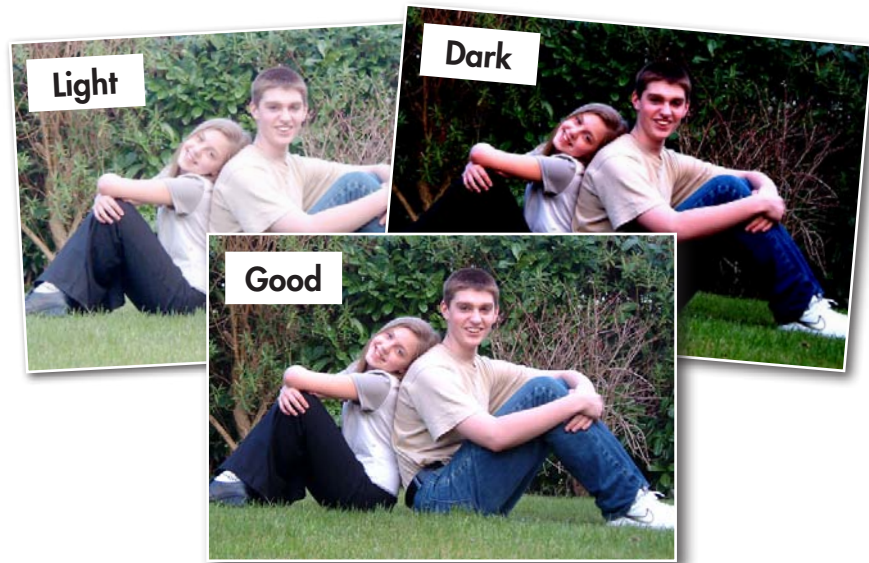

Exposure is the amount of light that falls on the film. The word “photography” comes from Greek words meaning “to draw with light.” Light is the photographer’s best friend—and worst enemy! Exposure to too much light, called overexposure, will make a picture look washed out, while exposure to too little light, called underexposure, will result in a too-dark picture.

Professional photographers use such tools as light meters, flood lamps, and light-reflecting screens to help them get the correct exposure. Or they may use a flash to make a sudden burst of light, brightening a dim scene. On simple cameras, the flash is built in, and some activate automatically whenever light levels are low.

Lighting **Dos** and **Don'ts**

- ◆ Don't shoot directly into light. A subject in front of a window where daylight is streaming in may end up looking shadowy and dark in the photograph. Don't shoot with light coming from the side unless you want an image that is half in the light and half in the shadows.
- ◆ Do have light coming from behind you. But be careful on sunny days—a person looking into the sun may end up squinting in the picture. And make sure your own shadow isn't in the shot.
- ◆ Don't be afraid to use the flash, even when there seems to be enough light. It may help fill in dark spots and even the lighting.
- ◆ Do take the same outdoor shot at sunrise, noon, and sunset to see how the direction of the sunlight can change the look and mood of a photo.
- ◆ Photos of people with glowing “red eyes” happen frequently with inexpensive cameras. To avoid this, turn on more lights in the room and tell your subjects to shift their eyes so they are not staring right into the camera.

The focus, or sharpness of the image, is determined by the distance between the camera lens and the subject, and between the lens and the film or chip. Lenses can only focus on objects that are a certain distance away; most simple cameras focus best on objects about 5 feet (1.5 m) away. Advanced compact cameras come with motorized zoom lenses that move out to take close-up pictures or in for wide-angle shots at the push of a button.

Cameras are very sensitive mechanisms. Even the slightest movement may cause a blurry picture. To keep the camera steady:

- ◆ Hold it with both hands.
- ◆ Keep fingers and hair away from the lens and flash.
- ◆ Tuck your elbows into your sides.
- ◆ Stand with your legs slightly apart so you are balanced and comfortable.
- ◆ For more steadiness, crouch down on one knee or sit cross-legged with your elbows on your knees.
- ◆ Try pressing the camera against a tabletop or a wall.
- ◆ Squeeze the shutter-release button slowly and evenly.

Fun Photography Projects

A panorama is a long, continuous picture that shows a very wide view. It could be a spectacular city skyline, mountain range, beach scene, or simply the view from your front door. Choose an open location without too many objects in the foreground. Imagine the scene broken up into three to five different sections. Practice moving the camera across the view from left to right, or **panning**, without moving your feet. Take a series of photos so that each section overlaps the section before it by about one-third. What you see in the right-hand part of the first shot should be where the left-hand part of the next shot begins. Start at the left side of the scene and work your way toward the right. It's a good idea to take a few shots of each section.

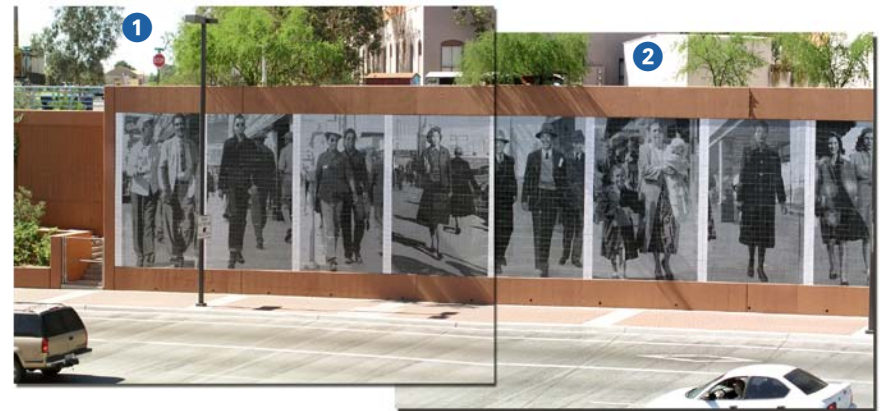

Overlapping four photos of a city mural created this panorama.

Next, lay out the photos so the right side of one matches the left side of the next. Glue or tape them together to form one continuous picture.

Here are some other fun photography projects.

- ◆ You can create cool effects by putting colored cellophane in front of a lens. This will block or reduce the color of the cellophane in your photo. What do you think will happen when you take a picture of a yellow car through a yellow filter?
- ◆ Try aiming the camera through the lens of polarized sunglasses. This helps screen out glare from shiny surfaces and bright sunlight.
- ◆ Make a frame filter by cutting shapes out of black construction paper and taping the paper to the front of the lens. Try star shapes, keyhole shapes, or arches, or use your imagination.



*We had a great time at Universal Studios . . .
3-D glasses and even a visit with Count Dracula!*

- ◆ Select your favorite photos and organize them in an album so they tell a story. Beneath each photo, write the date and place taken, identify the people, and describe what is going on.
- ◆ Don't discard the photos that don't come out well—make a collage. Cut out pieces of unwanted photos and arrange the images to your liking and paste them onto a poster.
- ◆ Create a line of greeting cards. Glue a photo of yourself, family, friends, places you've been to, sights you've seen, shots of wildlife and nature, and so on, onto a piece of paper folded in half. Write a personalized note inside.

Explore More

At the Library

Your local library or bookstore will have many books on photography. They will teach you how to produce great pictures of people, scenery, and weird and interesting things. Have your librarian help you find photography instruction books for kids. Look in your library's art section to find books with famous photographs. You can learn a lot about photography by studying the work of professional photographers.

On the Internet

- In the address window, type *www.google.com*.
- In the search window, type in the subject you want to learn about, such as *digital cameras* or *photography*. You might find more interesting Web sites if you include the phrase "for kids."
- Click "Search." Read the colored links and click on one that looks interesting.
- When you want to explore more links, click the "Back" button on the top left.

With Your Camera

One of the best ways to explore the world of photography is to take lots of pictures. Take a camera with you wherever you go. Think about how things around you might make good photographs. See if you can make works of art from the people, places, and objects around you. Don't worry about making mistakes when you're having fun with your camera.

Glossary

amateur (<i>adj.</i>)	not professional; someone who does something as a hobby (p. 9)
composition (<i>n.</i>)	how the objects are arranged in a picture (p. 16)
crude (<i>adj.</i>)	simple and not very well-designed (p. 5)
cumbersome (<i>adj.</i>)	heavy and awkward to carry (p. 4)
daguerreotypes (<i>n.</i>)	old-fashioned photographs invented by Louis Daguerre (p. 7)
darkrooms (<i>n.</i>)	closed rooms, lit by dim red light, where a photographer develops film into prints (p. 13)
exposure (<i>n.</i>)	the amount of light that falls on film (p. 19)
multipurpose (<i>adj.</i>)	designed or used for many different things (p. 14)
painstaking (<i>adj.</i>)	taking much precise and time-consuming work (p. 9)
panning (<i>v.</i>)	moving the camera from side to side from one position (p. 22)
shutter (<i>n.</i>)	the part in a camera that, when triggered, briefly allows light to enter the lens (p. 5)

Index

daguerreotype, 7	negative, 12, 13
darkroom, 13	panorama, 22, 23
film speed, 14	pinhole camera, 5, 6
flash, 10, 11, 19, 20	zoom lens, 10, 11, 21